

## **NUMERICAL SIMULATION OF THE PENDULUM TEST WITH A GLASS PLATE**

### **RECHNERISCHE ERFASSUNG DES PENDELSCHLAGVERSUCHS MIT EINER GLASSCHEIBE**

### **SIMULATION NUMERIQUE D'UN ESSAIE AVEC UNE VITRE DE SECURITE SOUS L'ACTION DE CHOC AVEC UN PENDULE**

Roland Rück, Michael Weschler

#### **SUMMARY**

Finite element analysis was carried out simulating the pendulum test with a plate of fully tempered glass. Three different model types of the impact body were compared. Material properties of these models were used in order to approach the solutions to the test results. The model with the cylindrical shape turned out to be a good compromise regarding two important attributes – quality of the results and convergence property of the nonlinear solution.

#### **ZUSAMMENFASSUNG**

Finite-Elemente-Berechnungen wurden zur Simulation des Pendelschlagversuchs mit einer absturzsichernden ESG-Scheibe durchgeführt. Dabei wurden drei verschiedene Stoßkörpermodelle miteinander verglichen. Die Anpassung an die Versuchsergebnisse erfolgte über die Variation von Materialparametern. Es zeigte sich, dass das Stoßkörpermodell mit zylindrischer Form einen guten Kompromiss zwischen der Übereinstimmung der Rechenergebnisse mit den Versuchsergebnissen auf der einen Seite und dem Konvergenzverhalten der nichtlinearen Rechnung auf der anderen Seite darstellt.

#### **RESUME**

Calculations avec un programme des éléments finis étaient réalisé pour simuler un essai avec une vitre de sécurité sous l'action de choc avec un pendule. Trois modèles du corps du choc ont été comparé. Les résultats numériques ont été ajusté aux résultats expérimentals à l'aide de variation de la constante propre aux matériaux. Le modèle du corps du choc avec la forme cylindrique et un compromis utilisable entre deux attributs importants – le qualité des resultats et la convergence d'analyse non-linéaire.

## 1. INTRODUCTION

If glass plates are used as a safety device against the violent downfall of persons, pendulum tests will be demanded. Therefore tests are carried out with the impact body described in E DIN EN 12 600 and drop heights between 450 mm and 900 mm. Since the tests are involved with considerable charges and with an expense of time, attempts were made to develop a numerical simulation of this pendulum test in case of constructions with simple supports. Due to considerable deflection, nonlinear geometric effects must be taken into account.

Lately tests were carried out to receive measured quantities for the evaluation of the numerical simulation ([DIBt, 1999] and [DIBt, 2000]). Proposals were drawn up in [DIBt, 2000] dealing with the modeling of the impact body and the impact problem in general.

The solution of transient dynamic FE-Analysis is compared with these test results. The influence of different impact body models and the influence of material properties is discussed.

## 2. IMPACT BODY

The impact body described in E DIN EN 12 600 consists of two wheels lying upon each other. The nominal diameter of the tires is 389 mm, the nominal breadth is 102 mm. According to the latest agreements the tire pressure is 4 bar irrespective of the drop height. Steel cylinders are fixed to the rims of the wheels so that the mass of the whole symmetrical impact body is  $m = 50$  kg (Fig. 1).

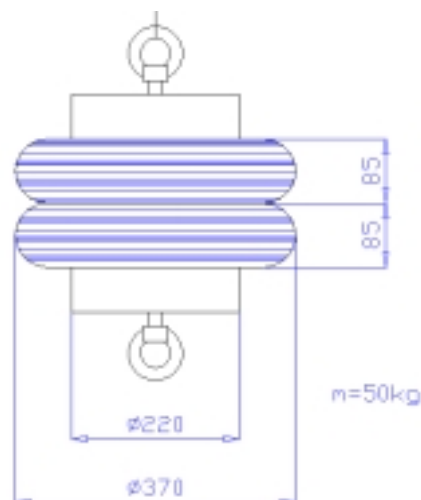

Fig. 1: Impact body of the Otto-Graf-Institut with the actual dimensions in mm

All tested impact body models consist of an inner part, the core, which represents the steel cylinders of the real impact body. The outer part, so called cover, simulates the tires. The real structure of a tire is very complex. With regard to the run time of the numerical solution process, the cover was modeled simplified as a homogeneous solid with low rigidity and small density.

The impact body models differ in their geometry. The shape of the model described in [DIBT, 2000] is a sector of a cylinder. The other models are shaped like a hemisphere and two halves of a toroidal volume with a cylindrical core (Fig. 2). In the following the models are called like their basic shape (cylinder-, sphere- and torus-model). Important characteristics of the models are contrasted in Table 1.

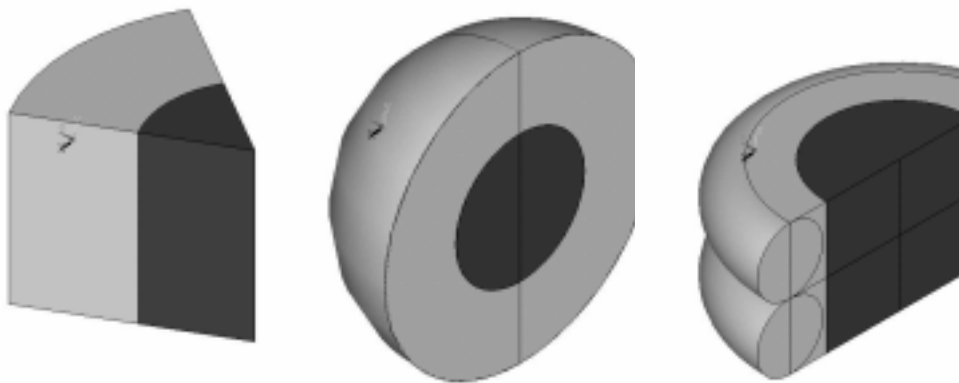

Fig. 2: Cylinder-model from [DIBt, 2000], sphere-model and torus-model

Table 1: Characteristics of the impact body models

	Test	Finite Element Analysis		
Name:	Wheel	Cylinder [DIBt, 2000]	Sphere	Torus
Shape of the cover:	Double curvature: Radii $R_1 = 185 \text{ mm}$ $R_2 \sim 42,5 \text{ mm}$	Single curvature: Radius $R = 194,5 \text{ mm}$ Height $H = 180 \text{ mm}$	Double curvature: $R = 194,5 \text{ mm}$	Double curvature: $R_1 = 195 \text{ mm}$ $R_2 = 45 \text{ mm}$
Shape of the contact area:	Point	Line	Point	Point
Number of the contact areas:	2	1	1	2

### 3. EXPERIMENTAL RESULTS

Results from the pendulum tests with a plate of fully tempered glass (ESG) were compared to solutions of the FE-Analysis with the different models. The size of the simply supported rectangular glass plate was  $b \times h = 1050 \times 2056$  mm<sup>2</sup>, the nominal thickness was 8 mm, the actual thickness was 7,75 mm. The plate was assembled in a frame with a great stiffness. Hence the elasticity of the support was not taken into account. The target was the center of the plate.

The test equipment, the setup and the test procedure were the same as described in [DIBt, 1999] and [Rück, 1999]. The maximum values of horizontal and vertical strain ( $e-H$  and  $e-V$ ) in the middle of the plate and the maximum of impact body acceleration were chosen for comparison.

Additional results from an impact on a rigid wall from [DIBt, 2000] were used.

### 4. FINITE ELEMENT ANALYSIS

#### 4.1 Modeling

The numerical analysis was done with the FE-Program ANSYS Rev. 5.6. Shell elements with the actual plate thickness of 7,75 mm were used to mesh the rectangle, which represented the plate of fully tempered glass (ESG). The solid models of the impact bodies were meshed with 3-D-solid elements with 20 nodes and hexahedral or tetrahedral shape. Because of the symmetry of loading, only a quarter of the plate and the impact body was modeled.

To solve the contact problem, special contact elements were overlaid on the areas of the model that were analysed for interaction. The glass plate was defined as target and therefore the surface was modeled with the element type TARGE170. The contact area on the impact body was modeled with the element type CONTA174. The impact speed  $v_0$  was calculated with the drop height  $h$  (Eq. 1) and was applied to the nodes of the impact body model as initial condition.

$$v_0 = \sqrt{2 \cdot g \cdot h} \quad (1)$$

## 4.2 Material Properties

Material properties are shown in Table 2. The whole mass of  $m = 50$  kg should be concentrated in the core of the impact body model. The density of the core material was calculated respectively. Due to the shape of the core, these calculated values differ more or less from the real density of steel. For the density of the cover material a small value of  $1 \cdot 10^{-7}$  kg/dm<sup>3</sup> was chosen. The remaining material properties (Young's modulus  $E_{\text{cover}}$  and Poisson's ratio  $\mu_{\text{cover}}$ ) were used as calibration parameters.

Table 2: Material properties

		Young's modulus E	Poisson's ratio $\mu$	Density $\rho$
		N/mm <sup>2</sup>	-	kg/dm <sup>3</sup>
Glass plate		70.000	0,23	2,5
Core	Cylinder	210.000	0,30	62,00
	Sphere			30,16
	Torus			17,68
Cover		Calibration parameters		$1 \cdot 10^{-7}$

## 4.3 Results

### 4.3.1 Influence of Element Size

First the element size was varied while the material properties were kept constant. Due to different shape of the models, the determined value of element edge length caused a different number of elements, nodes and degrees of freedom.

The influence of the tested sizes on the results within each model type is not considerable. But there are great differences between the run time values.

If the results from different models were compared, it can be stated, that the center deflection, the horizontal strain and the acceleration of the impact body are almost equal. But there are remarkable differences in the vertical strain values and therefore in the strain quotient  $\frac{e-V}{e-H}$  between the results calculated with the cylinder- and the torus-model on the one hand and the sphere-model on the other hand. The higher values of vertical strain in case of the sphere-model are caused by the punctual contact area, whereas the loading is distributed on a

line in case of the cylinder-model. The torus-model distributes the loading nevertheless on two punctual areas which are shifted in vertical direction.

*Table 3: Influences of model-type and element size*

		Impact body model										
		Cylinder			Sphere				Torus			
Element size	mm	15	22,5	45	40	50	70	120	30	45	70	80
Model size												
Elements	-	610	324	214	777	580	359	286	1216	583	488	369
Nodes	-	2134	801	242	1044	745	421	287	1717	780	615	453
Degree of freedom	-	4588	1919	840	3160	2321	1405	1063	4323	2098	1720	1255
Run time	min	58	6	1	12	6	2	1	31	6	6	2
Results												
Deflection	mm	31,06	31,09	31,03	31,16	30,45	31,15	31,35	31,26	31,38	31,29	31,78
Strain e-H	µm/m	1998	2006	2010	2056	1978	2062	2099	2014	2011	2024	2015
Strain e-V	µm/m	1359	1359	1371	1599	1520	1582	1699	1391	1396	1422	1387
Acceleration a	m/s <sup>2</sup>	201,7	201,6	203,0	204,0	205,8	206,0	201,1	212,2	209,7	217,6	216,2
e-V / e-H	-	0,680	0,677	0,682	0,778	0,768	0,767	0,809	0,691	0,694	0,703	0,688
<b>Notes:</b>												
Plate of fully tempered glass (ESG) with thickness $d = 7,75$ mm and size $b \times h = 1050 \times 2056$ mm <sup>2</sup>												
Cover material with $E_{\text{cover}} = 1,3$ N/mm <sup>2</sup> and $\mu_{\text{cover}} = 0,4$												
Impact speed $v_0 = 2,97$ m/s corresponding to a drop height of $h = 450$ mm												
The noted deflections and strains are the maximum values in the center of the plate.												
The acceleration a ist the maximum value of the impact body acceleration. The retardation hereat is defined positive.												

For further analysis the cylinder-model with an element size of 22,5 mm was chosen. Comparative calculations were done with the sphere-model and the torus-model with element size of 40 mm and 45 mm. Mesh quality especially at the contact area was the most important criterion for the decision (Fig. 3).

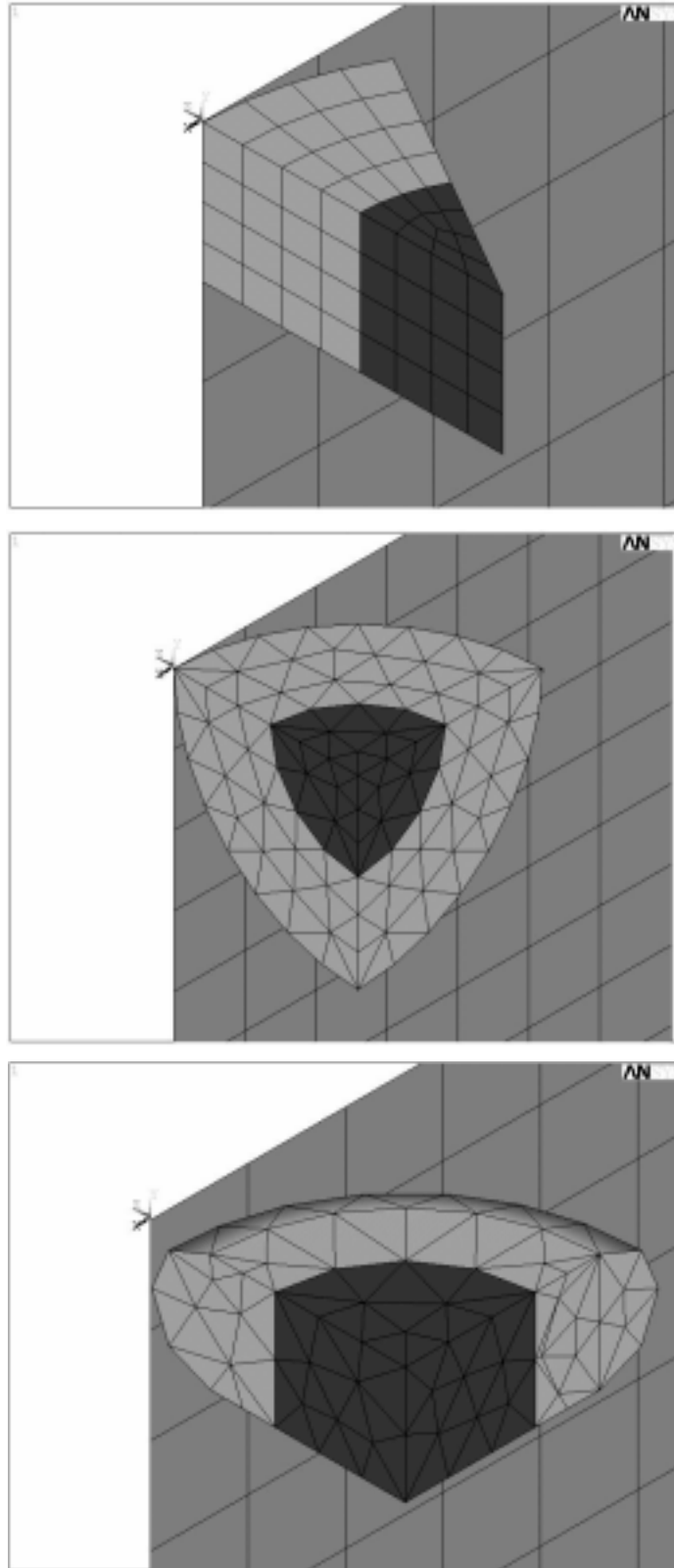

*Fig. 3: Meshed impact body models – cylinder, sphere and torus*

### 4.3.2 Influence of Cover Material Properties

#### 4.3.2.1 Static Loading

Submitted to a static loading of  $F = 10$  kN, the cylinder-model of the impact body was analysed. The Poisson's ratio was constantly  $\mu_{\text{cover}} = 0,4$ , the Young's modulus varied between 1,0 and 2,0 N/mm<sup>2</sup>.

In the comparative test the real impact body was fixed on a rigid support. Then it was loaded directly on the steel cylinders (Fig. 4). The force was increased displacement-controlled with a speed of 0,1 mm/s up to the maximum of  $F = 10$  kN.

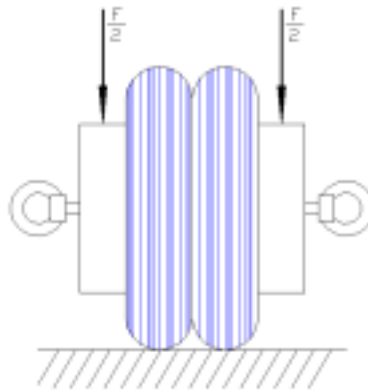

Fig. 4: Test with the real impact body and static loading

The FE-Analysis results obtained with a Young's modulus  $E_{\text{cover}} = 1,3$  N/mm<sup>2</sup> fitted best the test results (Table 4). Fig. 5 shows the load-displacement-curve of the test and the curve of the FE-Analysis with the cylinder-model and  $E_{\text{cover}} = 1,3$  N/mm<sup>2</sup>.

Further a series of similar experiments was carried out with static loading increased step by step. After each load step the load was decreased and the contact area between the tires and the rigid support was measured (Fig. 6).

Table 4: Results of the analysis with static loading ( $F = 10$  kN)

		Test	FE-Analysis (cylinder)			
E-cover	N/mm <sup>2</sup>	-	1,0	1,3	1,6	2,0
Displacement	mm	31,5	33,2	30,6	26,5	22,8



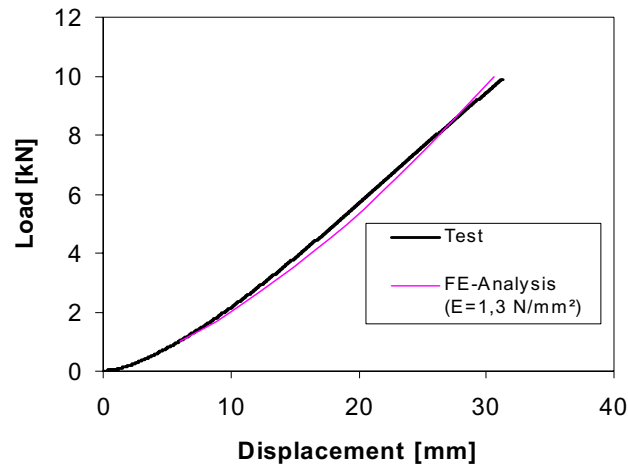

Fig. 5: Load-displacement-curves

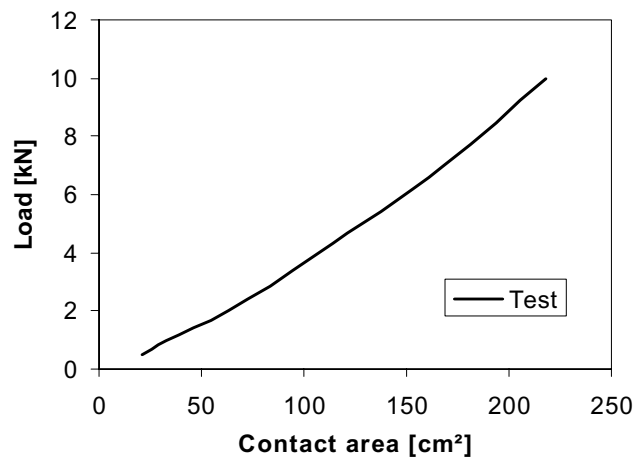

Fig. 6: Contact area between tires and rigid support (static loading)

#### 4.3.2.2 Impact on a rigid wall

An impact on a rigid wall with a drop height of  $h = 450$  mm was simulated using the three models cylinder, sphere and torus. In case of the cylinder-model the Young's modulus of the cover varied between 1,0 and 2,0 N/mm<sup>2</sup>. The Poisson's ratio was  $\mu_{\text{cover}} = 0,4$ . Again there was the best fit with  $E_{\text{cover}} = 1,3$  N/mm<sup>2</sup>. Therefore the analysis with the other models were done only with this value (Table 5). The test results were described in [DIBt, 2000].

 Table 5: Results of the analysis with an impact on a rigid wall (drop height  $h = 450$  mm)

		FE-Analysis						Test
		Cylinder				Sphere	Torus	[DIBt, 2000]
E-cover	N/mm <sup>2</sup>	1,0	1,3	1,6	2,0	1,3	1,3	-
Displacement	mm	42,8	38,5	35,3	32,1	40,9	39,2	-
Acceleration	m/s <sup>2</sup>	251,1	276,6	298,0	321,1	297,3	311,2	279
<u>Notes:</u>		Poisson's ratio $\mu_{\text{cover}} = 0,4$						

## 4.3.2.3 Impact on a glass plate

Next an impact on the center of a plate of fully tempered glass (ESG) described in Section 3 was analysed. The influence of the Young's modulus and the Poisson's ratio of the cover material was examined. The drop height was  $h = 450$  mm. The best approach to the test results was found with  $E_{\text{cover}} = 1,0$  N/mm<sup>2</sup>. The maximum values of impact body acceleration are distinctly greater than the test results.

Table 6: Impact on the glass plate – Variation of the Young's modulus  $E_{\text{cover}}$

		FE-Analysis						Test
		Cylinder				Sphere	Torus	
E-cover	N/mm <sup>2</sup>	0,5	1,0	1,3	3,0	1,0	1,0	
Displacement w	mm	26,73	30,2	31,09	33,25	30,2	30,6	-
Strain e-H	µm/m	1589	1885	2006	2508	1918	1909	1860
Strain e-V	µm/m	1059	1302	1359	1559	1496	1357	1270
Acceleration a	m/s <sup>2</sup>	175,8	189,9	201,6	252	195,2	203,0	165
e-V / e-H	-	0,666	0,691	0,677	0,622	0,780	0,711	0,683
<u>Notes:</u>		$\mu_{\text{cover}} = 0,4$						
		Drop height $h = 450$ mm						

Table 7: Impact on the glass plate – Variation of the Poisson's ratio  $\mu_{\text{cover}}$

		FE-Analysis			Test
$\mu_{\text{cover}}$	-	0,30	0,40	0,49	-
Displacement w	mm	29,7	30,2	30,5	-
Strain e-H	µm/m	1852	1885	1936	1860
Strain e-V	µm/m	1287	1302	1327	1270
Acceleration a	m/s <sup>2</sup>	185,3	189,9	196	165
e-V / e-H	-	0,695	0,691	0,685	0,683
<u>Notes:</u>		E-cover = 1,0 N/mm <sup>2</sup>			
		Model: Cylinder			

The figures 7 to 9 proof the good conformity of the time-dependent quantities.

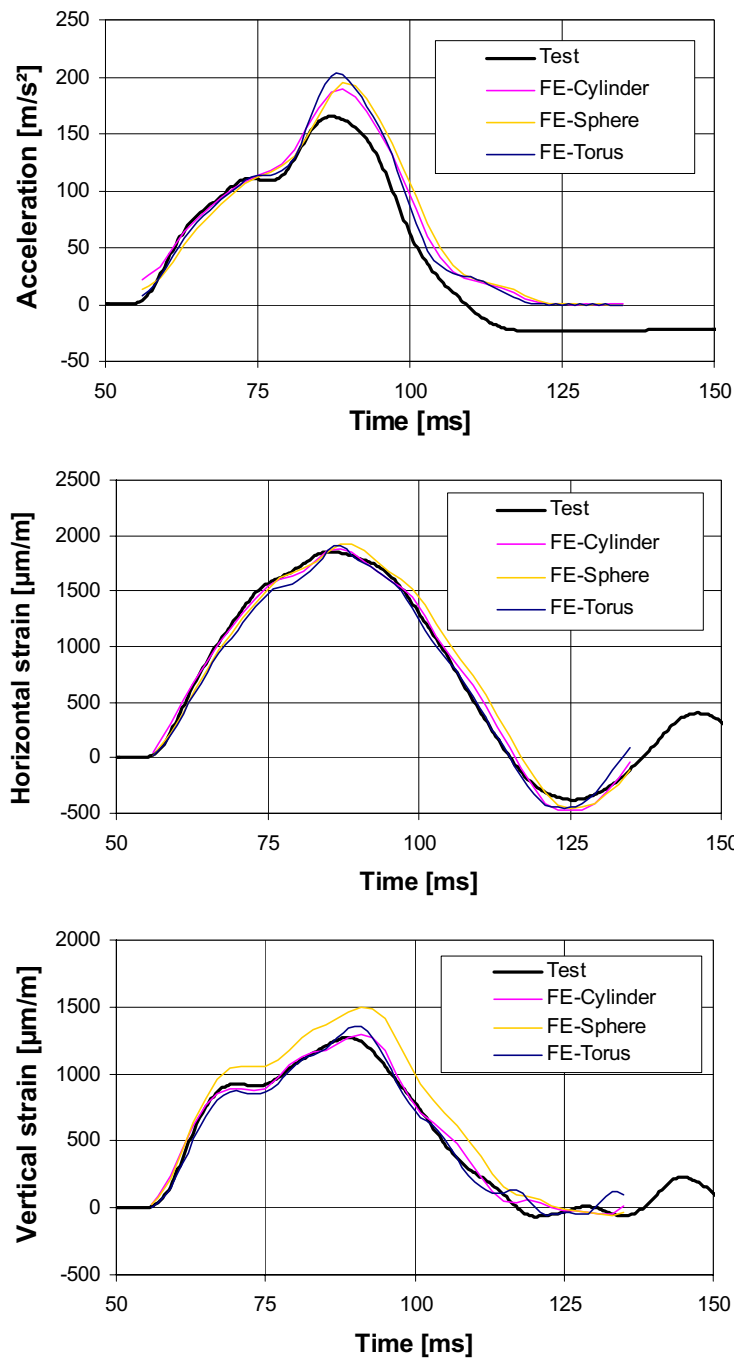

Figures 7 to 9: Time-dependent results of test and FE-Analysis  
 ( $E_{cover} = 1,0 \text{ N/mm}^2$  and  $\mu_{cover} = 0,4$ )

### 4.3.3 Influence of the Drop Height

The results of the tests with the glass plate, which had been carried out up to a drop height of 450 mm, are presented in Table 8 together with the FE-Analysis results with the impact body models cylinder, sphere and torus.

Table 8: Impact on the center of a glass plate - Variation of the drop height

	Drop height h	mm	5	20	100	200	450	700	900	1200
	Impact speed v-0	m/s	0,313	0,626	1,401	1,981	2,971	3,706	4,202	4,852
Test	Acceleration a	m/s <sup>2</sup>	13,7	24,9	69,3	101,4	165,1	-		
	Strain e-H	µm/m	294	500	1095	1402	1858			
	Strain e-V	µm/m	176	303	678	888	1273			
	Stress s-H	N/mm <sup>2</sup>	24,7	42,0	92,3	118,5	158,0			
FE-Analysis Cylinder	Displacement w	mm	3,7	7,7	16,4	21,9	30,2	35,3	38,5	1)
	Acceleration a	m/s <sup>2</sup>	12,7	28,1	74,3	114,1	189,9	251,5	288,6	
	Strain e-H	µm/m	230	478	1014	1360	1885	2247	2483	
	Strain e-V	µm/m	154	324	705	942	1302	1541	1614	
	Principle stress s1	N/mm <sup>2</sup>	19,62	40,7	86,6	115,8	160,0	190,2	210,0	
FE-Analysis Sphere	Displacement w	mm	-			21,7	30,2	35,5	39,2	43,4
	Acceleration a	m/s <sup>2</sup>				113,8	195,2	261,9	314,9	370,0
	Strain e-H	µm/m				1401	1918	2269	2503	2796
	Strain e-V	µm/m				1115	1496	1736	1908	2019
	Principle stress s1	N/mm <sup>2</sup>				121,8	166,7	196,4	215,4	240,2
FE-Analysis Torus	Displacement w	mm	-			22,0	30,6	36,1	1)	
	Acceleration a	m/s <sup>2</sup>				116,9	203,0	279,4		
	Strain e-H	µm/m				1341	1909	2325		
	Strain e-V	µm/m				943	1357	1676		
	Principle stress s1	N/mm <sup>2</sup>				114,5	162,9	199,5		

Notes: 1) Solution not converged

Plate of fully tempered glass (ESG) with thickness d = 7,75 mm and size b x h = 1050 x 2056 mm<sup>2</sup>

Cover material with E-cover = 1,0 N/mm<sup>2</sup> and µ-cover = 0,4

The deflections, strains and the stress are the maximum values in the center of the plate.

The acceleration a ist the maximum value of the impact body acceleration (retardation is positive).

The figures 10 to 13 show the maximum values of the impact body acceleration, the strains e-H and e-V and the first principle stress dependent on the impact speed.

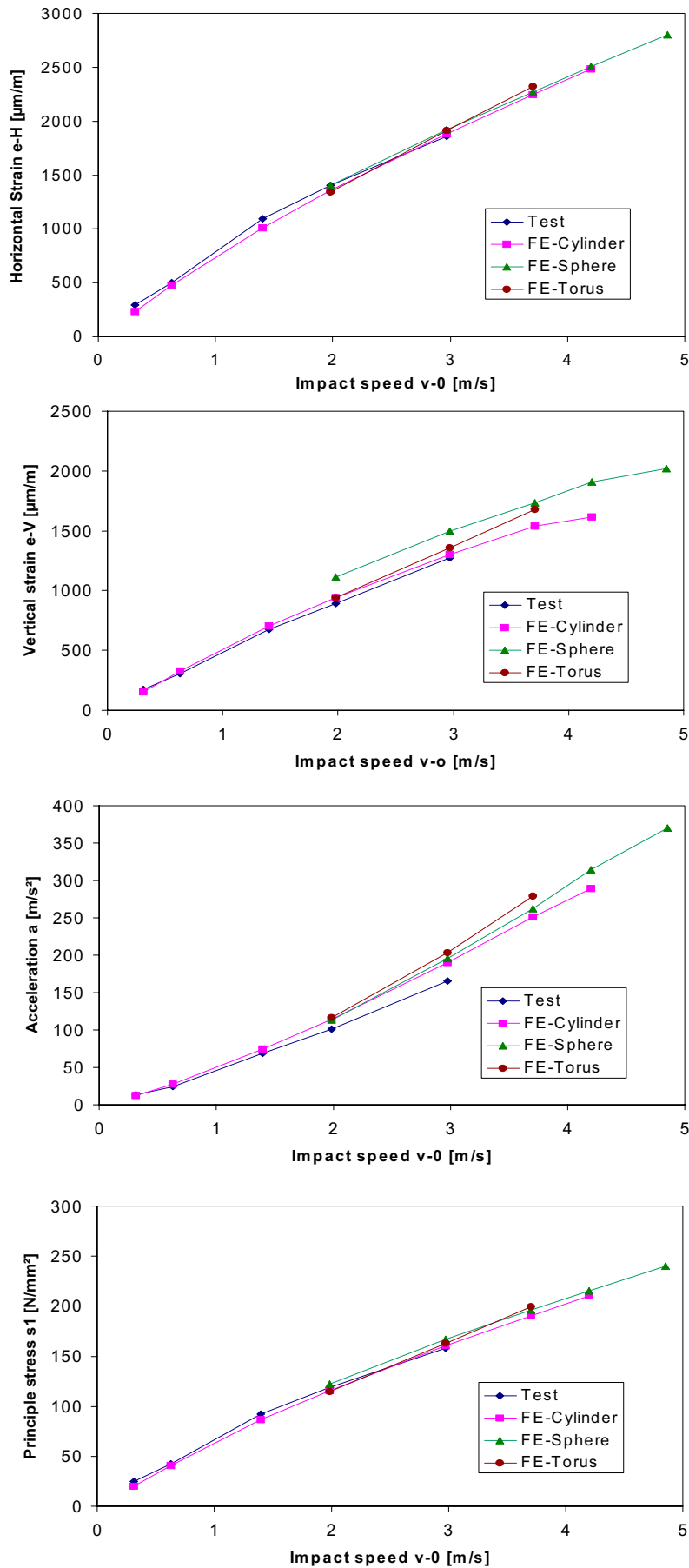

Figures 10 to 13: Impact on the center of a glass plate – Maximum values dependent on the impact speed

## 5. CONCLUSION

Numerical analysis with the finite element program ANSYS Rev. 5.6 were carried out simulating the pendulum test with a glass plate to study the influences of modeling, meshing and material properties.

In the following some essential results are compiled briefly:

- The shape of the impact body model can be simplified. The body should consist of a rigid core, in which the mass is concentrated, and a cover material with a low rigidity. The material properties of this cover material can be used for calibration purpose.
- The model with the shape of a sector of a cylinder is an efficient compromise between the quality of the results and the convergence property. The sphere-model had the best convergence characteristic but the vertical strain was over-estimated. The third model with a toroidal cover and a cylindrical core has the most realistic shape, but the convergence quality was the worst.
- The time-dependent results of the analysis are close to the measured values. The acceleration of the impact body is over-estimated.

## REFERENCES

- DIBt (1999): Deutsches Institut für Bautechnik, Projektgruppe Absturzsicherung (Hrsg.), Völkel, G.E.; Rück, R. (Autoren): Untersuchung von 4-seitig linienförmig gelagerten Scheiben bei Stoßbelastung, Deutsches Institut für Bautechnik, 1999
- DIBt (2000): Deutsches Institut für Bautechnik, Projektgruppe Absturzsicherung (Hrsg.), Wörner, J.-D.; Schneider, J. (Autoren): Abschlußbericht zur experimentellen und rechnerischen Bestimmung der dynamischen Belastung von Verglasungen durch weichen Stoß, Deutsches Institut für Bautechnik, 2000
- Rück (1999): Rück, R.: Stoßbeanspruchung einer vierseitig linienförmig gelagerten Verglasung durch menschliche Körper und Ersatzkörper in Festschrift zum 60. Geburtstag von H.-W. Reinhardt, Stuttgart 1999, pp. 319-337