

## TEST RESULTS FROM SUSPENSION CABLES PRELOADED IN PRACTICE

### ERKENNTNISSE AUS DER PRÜFUNG BAUPRAKTISCH VORBELASTETER BRÜCKENSEILE

### RESULTATS D'ESSAIS SUR DES CABLES DE SUSPENSION PRECHARGES EN PRATIQUE

Wolfgang Harre

**Summary.** The report deals with test results of suspension cables, which were dismantled from existing bridges after more than 25 years in service and then tested under static and dynamic loadings.

The aim of these tests is to extend the presently incomplete knowledge of fatigue behavior of suspension cables for bridges. Beside the evaluation of a  $\sigma$ -N-curve (Wöhlerlinie) for preloaded cables in general, these investigations were carried out to gain reliable informations concerning the extension of damages and the remaining fatigue life of cables practically preloaded in existing bridges over many years.

The results until now show a remarkably high remaining fatigue strength. Furthermore the tests made obvious that fretting corrosion has a dominating influence on the extension of damages. The introduced stress range  $\Delta\sigma$  is the most effective load parameter governing the fatigue strength.

**Zusammenfassung.** Es wird über Untersuchungen an Brückenseilen berichtet, die nach über 25jähriger Betriebsbeanspruchung in Brückenbauwerken ausgebaut und anschließend statischen und dynamischen Belastungsversuchen unterworfen wurden. Ziel dieser Versuche ist es, die bislang noch spärlichen Kenntnisse zum Ermüdungsverhalten vollverschlossener Brückenseile schrittweise zu erweitern. Neben der Aufstellung einer ausreichend belegten Wöhlerlinie für vorbelastete Seile, für die Beurteilung des Ermüdungsverhaltens von Brückenseilen generell, geht es vor allem darum, zuverlässige Informationen zum Schädigungsverlauf und zur Restlebensdauer baupraktisch vorbelasteter Seile zu sammeln.

Die bisherigen Ergebnisse lassen u.a. eine bemerkenswert hohe Resttragfähigkeit sowie einen dominierenden Einfluß der Reibkorrosion beim Schädigungsverlauf erkennen. Die einwirkende Schwingbreite der mechanischen Beanspruchung  $\Delta\sigma$  erweist sich als vorherrschender ermüdungswirksamer Belastungsparameter.

Résumé. Un rapport est donné des études réalisées sur des câbles de suspension qui après 25 années de service dans des ponts existants ont été démontés et soumis à des essais sous charges statiques et dynamiques. Il était le but de ces essais d'élargir les connaissances encore incomplètes sur la résistance à la fatigue de câbles. A côté de l'évaluation d'une courbe  $\sigma$ -N (Wöhlerlinie) pour les câbles préchargés les investigations ont été réalisées pour gagner des informations sérieuses sur l'extension des dégâts et la durée de vie restante de câbles préchargés dans des ponts existants.

Les résultats déterminés jusqu'à présent revèlent une résistance à la fatigue restante remarquable ainsi qu'une influence dominante de la corrosion par frottement sur l'extension des dégâts.  $\Delta\sigma$  s'avère comme paramètre le plus effectif qui domine la résistance à la fatigue.

Key words

Cables, cable-stayed structures, fatigue.

## 1. INTRODUCTION

Despite the spread use of cables as tension members in bridge structures since many decades, the knowledge concerning the fatigue behavior of these cables is still very poor. Neither a sufficiently supported  $\Delta\sigma$ -N-curve (Wöhler-diagram) is known, nor the substantial proof of a fatigue strength limit for such cables really exists. Completely unknown is the effect of variable amplitude loading, i.e. the increase of fatigue strength respectively fatigue life when the fatigue loading changes from constant amplitudes to variable amplitudes, the more realistic loading. Testing with variable amplitudes related to the practice will shift the WÖHLER-diagramm ( $\Delta\sigma$ -N-curve for constant amplitude loading) towards a higher fatigue strength equivalent a longer fatigue life. The amount of increase in fatigue life depends on the amplitude spectrum.

In consequence of the lack of comprehensive basic knowledges concerning their fatigue behavior, the cables for every cable-stayed bridge going under construction have to pass a standard test program according to formerly DIN 1073 respectively now DIN 18809, which has no relationship at all to practice and which represents a very unsatisfactory proceeding since many decades! There are mainly two reasons for the lack of basic knowledges: a) in the earlier past no suitable testing equipment was available to run tests under random load conditions as well as with comparatively high forces (~1 to 10 MN), and b) to create a complete WÖHLER-diagram or  $\Delta\sigma$ -N-curve requires a great number of specimens, i.e. the enormous financial expense even only for the specimens (the fabrication costs for one test cable of about 5 m of length, with anchorages, in a medium diameter of for instance 75 mm are estimated

of about 25 000,-- DM) has prevented until now the realization of any proposed test program.

Nowadays the situation has somewhat changed: Suitable testing equipments are developed and available. However the fabrication costs of the specimens remain still extraordinarily high, so that extensive and systematical investigations on new fabricated test specimens of cables will be quasi out of reach now and in the near future. On the other hand, there are meanwhile several cable-stayed bridges in service, which will be or should be overhauled partly or completely soon. In the course of such bridge "renovations" the cables will often be replaced. Instead of scrapping them, the dismantled cables could be used on for experimental investigations as practically preloaded test specimens almost free of charge!

First aim of such investigations would be to set up a sufficiently covered WÖHLER-diagram of preloaded cables in the sense of a lowerbound-curve for the classification of the fatigue behavior of cables in general, as well as to obtain founded informations regarding the damage progress and the remaining fatigue life of preloaded cables.

The recently accomplished investigation program, carried out at the Otto-Graf-Institut, on dismantled cables of the NORDERELBE-bridge near Hamburg and of the FEHMARN-SUND-bridge to Denmark can be considered as a first step in the above described direction.

The gained results--partly contradictory--reveal the considerable deficit in knowledge at present and the actual inability to evaluate the fatigue strength, the influence of damaging factors and the remaining fatigue life of cables. In this report, the most important results of the

conducted investigations up to now are presented in a compact form and conclusions are pointed out.

## 2. FEHMARNSUNDBRIDGE

### 2.1 Statement of the problem

In 1980 the Otto-Graf-Institut was commissioned by the BUNDESMINISTERIUM FÜR VERKEHR to investigate a cable dismantled of the Fehmarnsundbridge. During an inspection and examination of the bridge by the BUNDESBahnZentralamt München, it was found out that some of the 80 suspension cables had a badly corroded surface. The protection against corrosion came partly off, the gaps between the wires in the outer layer were opened and there were intense corrosion induced pittings. As a decision base for the necessary sanitation, the dismantled cable should be subjected to detailed material testing and technological investigations. In this report, only the most important mechanical-technological results will be presented. More detailed informations can be found in [1].

### 2.2 Testing program

The following testing program was arranged and carried out.

#### 2.2.1 Cable specimen A

Constant amplitude fatigue test with  $\Delta\sigma = 125 \text{ N/mm}^2$ ,  $N_G = 3,3 \cdot 10^6$  cycles; afterwards a constant amplitude fatigue test with  $\Delta\sigma = 200 \text{ N/mm}^2$  until  $N = 0,20 \cdot 10^6$  cycles; afterwards a statical rupture tension test.

### 2.2.2 Cables specimen B

Constant amplitude fatigue test with  $\Delta\sigma = 125 \text{ N/mm}^2$ ,  $N_G = 2,0 \cdot 10^6$  cycles; afterwards a constant amplitude test with  $\Delta\sigma = 200 \text{ N/mm}^2$  until  $N = 0,50 \cdot 10^6$  cycles.

The tests were conducted in a hydraulic 5-MN testing machine, see figure 1.

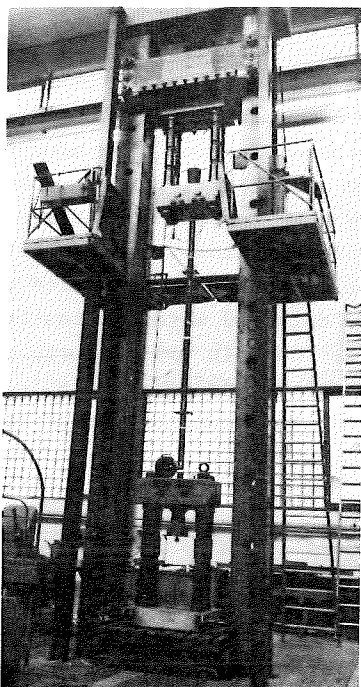

Fig. 1. Test setup

### 2.3 Fabrication of the cable specimens A and B.

Figure 2 shows where the cable selected for testing (D9') was taken from the bridge.

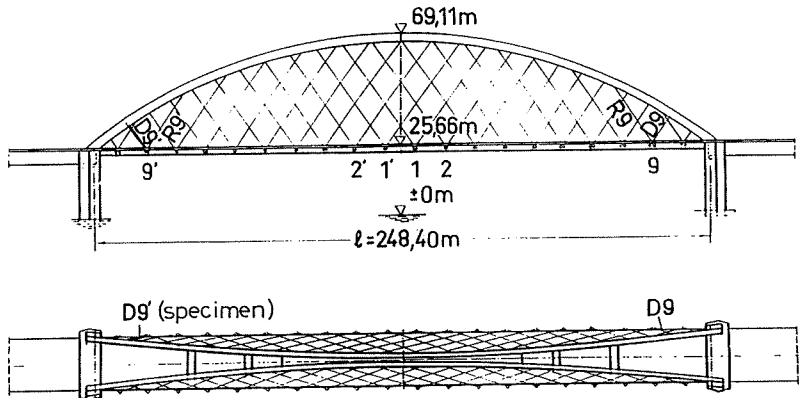

Fig. 2. Fehmarnsundbridge-survey

The cable, about 14,20 m long,  $\phi$  81 mm, was substantially divided into 3 different segments (see figure 3).

The upper part of the dismantled cable with a length of about 3,60 m was used for material- and corrosion tests. After cutting off the upper anchorage and extrusion of the anchor socket, the latter one was applied as anchorage to the upper end of cable specimen B.

Cable specimen A was made of the middle part (length = 5,40 m) of the dismantled cable by attaching special test anchor sockets on both ends.

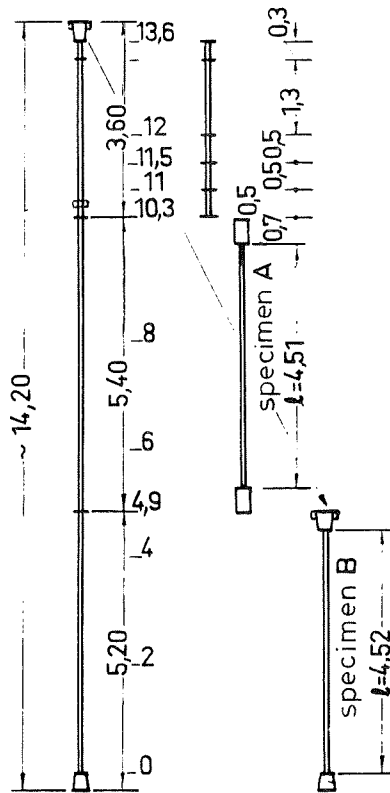

Fig. 3. Dividing of cable D9' into test specimens

From the lower part of the dismantled cable (length = 5,20 m) with the remaining original anchorage at the lower end, cable specimen B was made by attaching as mentioned above the anchor socket of the initially upper

cable part to the upper end of the test specimen.

The casting of the sockets was done by Thyssen Draht AG, Gelsenkirchen. Casting metal was ZnAl6Cu1 (Zamak 610). Test specimens A and B had a free cable length of 4,50 m each.

### 3. NORDERELBE BRIDGE

#### 3.1 Statement of the problem

When the highway bridge over the river Norderelbe near Hamburg (built in 1962) was subjected to a comprehensive sanitation in 1985, the Otto-Graf-Institut was commissioned by the BUNDESMINISTERIUM FÜR VERKEHR to investigate the dismantled cables  $\phi$  72 mm. On the base of the test results obtained from Fehmarnsundbrücke [1], the intention was to achieve further contributions and clarifying informations in the field of longtime fatigue behavior and remaining fatigue life of cables and cable-stayed bridges. Detailed descriptions are given in [2].

#### 3.2 Testing program

The following testing program was planned and conducted.

##### 3.2.1 Cable specimen C

The specimen was taken from the free length of the dismantled cable. Constant amplitude fatigue test with  $\Delta\sigma = 150 \text{ N/mm}^2$  and with simultaneously applied transverse pressure of 19 kN/cm. The same test was made in 1962 with a specimen of the new cables when the bridge was under construction. It was expected from this test repetition

to find out, whether the fatigue strength of the cables is reduced by the service over a period of more than 25 years and if yes, how much it is reduced.

### 3.2.2 Cable specimen D

The specimen was taken from the end area of the cable with an original anchorage kept on; constant amplitude fatigue test with  $\Delta\sigma = 150 \text{ N/mm}^2$ , no transverse pressure.

### 3.2.3 Cable specimen E

Constant amplitude test with an original cable-saddle, containing two cables turned around, one upon the other,  $\Delta\sigma = 150 \text{ N/mm}^2$ . The aim of this test was to study the behavior of the cables under realistic transverse pressure conditions existing in such saddle-or turn around structures with several layers of cables.

All the tests were designed to run until the provided limit number of cycles  $N_e = 2,0 \cdot 10^6$  is reached respectively until the recorded wire cracks increase progressively. At the end of the tests, a controlled opening of the cables and anchorages was planned in order to register the wire cracks and analyse the damage.

In the following report, only the most essential mechanical-technological results are presented. Further details and informations can be taken from [2].

The tests with the specimens C and D were carried out in the 5-MN testing machine in the same way like the tests with the specimens A and B of Fehmarnsundbrücke [1]. As to specimen E a special testing equipment had to be

developed (see figures 4 and 5), a detailed description of it is given in [2].

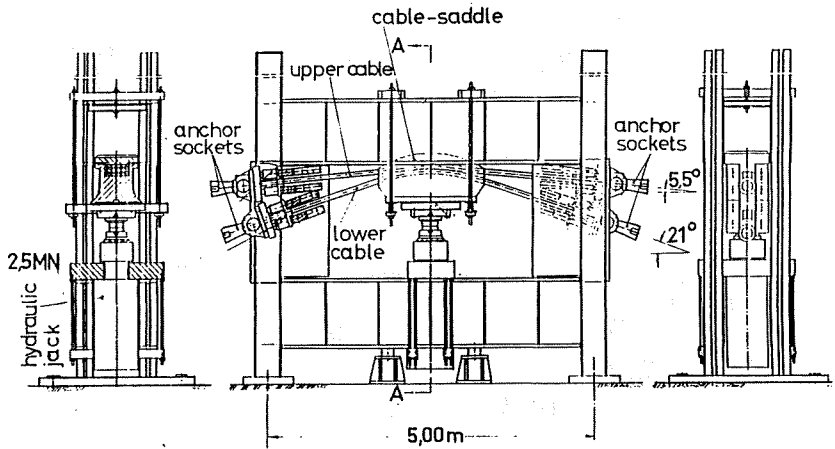

Fig. 4. Schematic diagram of test set-up

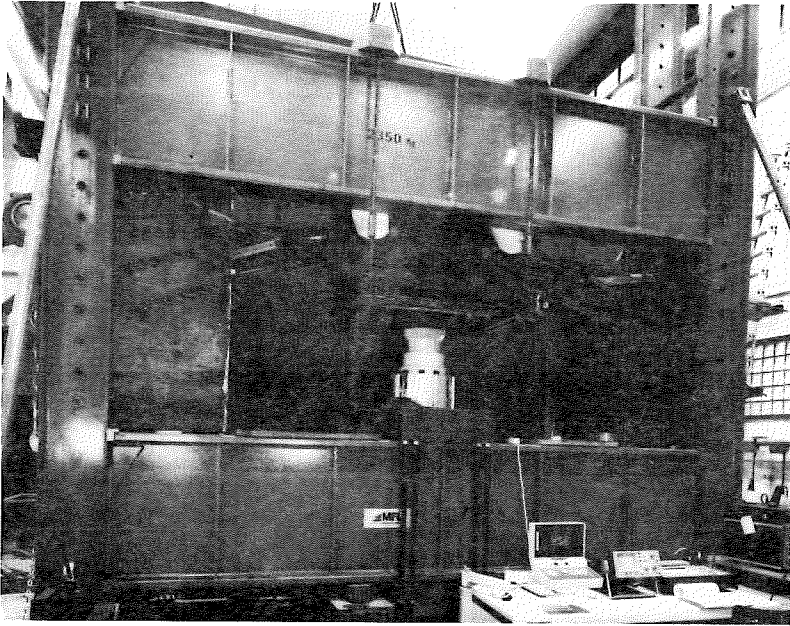

Fig. 5. Test set-up

### 3.3 Fabrication of the cable specimens C, D and E.

Fig. 6 shows the different points of the Norderelbe-bridge, where the parts for the specimens were drawn from. The cable bundles consisted of ten spiral wire ropes,  $\phi$  72 mm, arranged in two layers of five cables respectively.

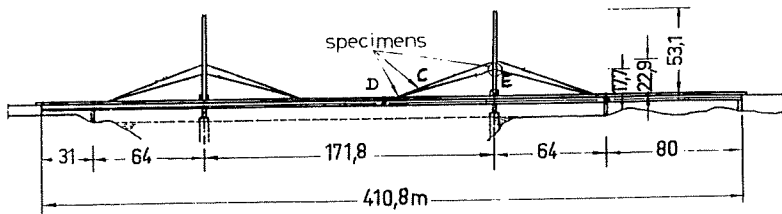

Fig. 6. Schematic diagram of the Norderelbebridge with the points where the specimens were drawn from

On both ends of the cable cutted to length for specimen C, anchor sockets taken from the bridge were attached. Casting material was again ZnAl6Cu1 (Zamak 610). In order to compare the test results of specimen C with those obtained in 1960 during the construction of the bridge, a transverse pressure equipment was installed in the same way like it was done at that time (details are given in [2]).

Specimen D was similar to C, however without transverse pressure equipment. One end of specimen C had the remained original anchorage whereas at the other end an anchorage taken from the bridge was attached by Thyssen Draht AG, using again Zamak 610.

Specimen E consisted of the so called cable-saddle and two fixed cables one upon the other of about 6 m length

respectively. From the initial ten cables (two layers by five) going over the saddle in the bridge, only the middle one of each layer was used for the fatigue test. At the four ends of the two cables anchorages taken from the bridge were attached by using a polymere resin material named Wirelock. This is different from all the other specimens filled with Zamak 610 and was caused by the fact, that it would have been very difficult to bring and to keep specimen E in an exact vertical position necessary while filling in Zamak 610 with a temperature of about +400°C into the sockets! Wirelock however is filled in under normal (room) temperatures.

#### 4. RESULTS AND CONCLUSIONS

The investigations performed on cables dismantled after more than 25 years in service from the Fehmarnsundbridge and the Norderelbebridge have yielded the following results and findings:

- a) After more than 25 years in service, the cables itself showed a remaining fatigue life of more than  $2,0 \cdot 10^6$  cycles. This can be stated for the cables "in relatively good condition" of the Norderelbebridge as well as for the cables "considerably damaged by corrosion" of the Fehmarnsundbridge. Consequently the tests have proved a still sufficient fatigue strength according to the relevant DIN specifications. Even after fatigue loading of more than 25 years, no significant loss of carrying capacity of the cables could be found, i.e. an increased risk of damage or failure did not yet exist for both bridges as far as the cables are concerned.

- b) Analysing the wire cracks observed during the investigations showed numerous proofs and confirmations for a dominating influence of fretting corrosion among all the known corrosive damaging phenomenas like tension crack corrosion, pitting corrosion etc.

Beside of the pure mechanical induced fatigue damaging process, the mechanical-chemical combined damaging by fretting corrosion exerts the most decisive influence on the reduction of lifetime of cable structures. The remarkable difference between the fatigue strength limit of the single wires ( $\Delta\sigma = 400 \text{ N/mm}^2$ ) and the fatigue strength limit of the complete cables ( $\Delta\sigma 150 - 200 \text{ N/mm}^2$ ) is mainly referred to the influence of fretting corrosion.

- c) Points of turn around the multi layered cable bundles (cable-saddles, turn around anchorages etc) which are usually characterized by high local transverse pressures, had always been considered therefore as very problematical details of cable structures related to the fatigue strength. On the base of the presented test results [1, 2], it can be pointed out that these details are less critical as formerly assumed. They can be classified as at least not more "delicate" than the anchorages of the cables.
- d) The acting stress rate  $\Delta\sigma$  (stress amplitude  $\sigma_o - \sigma_u$ ) has an essential influence on fatigue life of the cables.  $\Delta\sigma$  is the dominating parameter governing the fatigue life, whereas the level of the maximum stress  $\sigma_o$  is of subordinated influence as long as it is kept under the yield stress level.

On of the urgent aims of the investigations on preloaded cables is to improve the understanding and fundamental knowledge of the fatigue behavior of cables by means of the elaboration of a sufficiently supported  $\Delta\sigma$ -N-curve (WÖHLER-diagram). The set up of such a diagram however implies the derivation and the definition of a damage - and failing criterion corresponding to the actual cable behavior.

The failing of cables submitted to fatigue loading is fundamentally different from that of the usual steel structures: Depending upon structural boundary conditions and the grade of notch effect, damaging and destruction in usual steel structures proceeds more or less steadily after a first crack occurred and almost the whole fatigue life of the structure is related to the period before the first crack happened, i.e. the crack initiation phase representes usually a life period multiple of the period of crack propagation.

In contrast to this, observations and results of fatigue tests with cables have shown, that the first wire crack may occur comparatively soon without having any connection with or relation to the much later total failing of the cable. The first wire crack is therefore unsuitable to be used as a failing criterion. Moreover the cables consist of up to 300 single wires nowadays, i.e. the first crack of one wire in a cable has quasi only the dimension of a micro crack for instance in a welded steel structure. In the course of the continual fatigue loading a considerable number of wire cracks and breaks may occur succeeding one another in relatively short time (so called infection breaks) without causing immediately a total failure of the cable. The respective net sections are able to carry on the acting forces with corresponding

increased stresses. Only after a further number of cycles, when finally about 25 to 30 % of the wires are broken, a progressive ascent of the registered wire break accumulation curve can be observed, which clearly announces the approaching total collapse of the cable. The fatigue failure of cables can be characterized as a real tough rupture with a kind of previous notice.

The described phenomenas and findings underline the idea discussed at times by experts, to introduce as  $\Delta\sigma$ -N-curve (WÖHLER-diagram) for cables a 25 %-damage curve, i.e. a 25 %- wire crack line as a realistic base for the design of safe and economical cable-stayed structures. With the results obtained in the presented investigations [1, 2], a first sketch of a 25 %-damage curve - of course still sparsely supported - was developed, see figure 7.

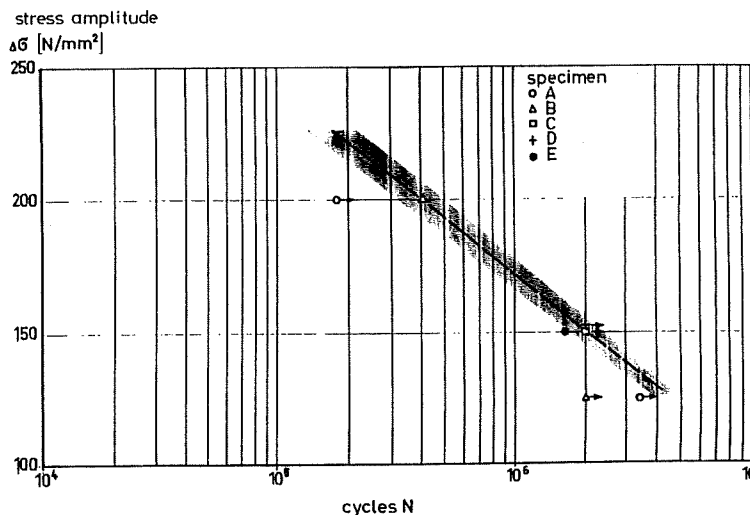

Fig. 7.  $\Delta\sigma$ -N-curve (WÖHLER-diagram) for preloaded cables on the base of 25 % wire crackes

The graph shows that the exponent of inclination of the curve comes out to  $K \approx 5,5$ . It is self-evident, that this first sketch has to be completed and extended by further investigations in order to reach a reliable and safe design base for cables submitted to fatigue loading. Only by means of initiatives like taken in the two projects of Fehmarnsundbridge and Norderelbebridge, the presently still very poor knowledge regarding the fatigue behavior of cables can be improved and brought to an adequate level in an economic way.

#### Literature

- [1] Harre, W. : Test results of preloaded cables dismantled from the Fehmarnsundbridge. Bauingenieur 66 (1991) H. 7, S. 301 - 309.
- [2] Harre, W. : Test results of preloaded cables dismantled from the Norderelbebridge. Bauingenieur 66 (1991), in preparation.